



The DRH370 is the top seller antenna for low-frequency measurement. DRH370 is massively used by many. With a high gain of up to 16 dBi and low VSWR, the DRH370 is suitable for EMC measurement, radio monitoring, and emission measurement.

Cloned antenna series are available through [AU Technology](#), which guarantees constant parameters.

Features and Specifications



Technical Performance

- Wide bandwidth
- Low return loss
- Individual calibration
- Suitable for EMC/EMI applications



Design and Surface Treatment

- Corrosion-resistant coating
- Includes standard mount



Manufacturing Technology

- Extremely durable
- High quality N type coaxial connector



Product Packaging Includes

- Linear polarized double ridged broadband horn antenna
- Universal antenna mount

Product Parameters

PRODUCT IDENTIFICATION

Product Name	DRH370
Product Category	Double Ridged Horn Antenna

ELECTRICAL SPECIFICATIONS

Frequency Range	370 MHz – 6 GHz
VSWR (max.)	1.6
VSWR (avg.)	1.2
Impedance	50 Ohm
Connector	N (female)
Power (CW / Peak)	600 W / 800 W
Antenna Factor	17 – 33 dB/m
Polarization	Linear

PHYSICAL SPECIFICATIONS

Width	370 mm (14.567 in)
Height	485 mm (19.094 in)
Depth	285 mm (11.220 in)
Weight	3.5 kg (7.716 lb)

OPERATING CONDITIONS

Rated Temperature Range	0°C – +50°C
Storage Temperature Range	-20°C – +70°C

MOUNTING FLANGE

Mounting	Universal antenna mount
----------	--------------------------------

Mechanical Drawings

Antenna

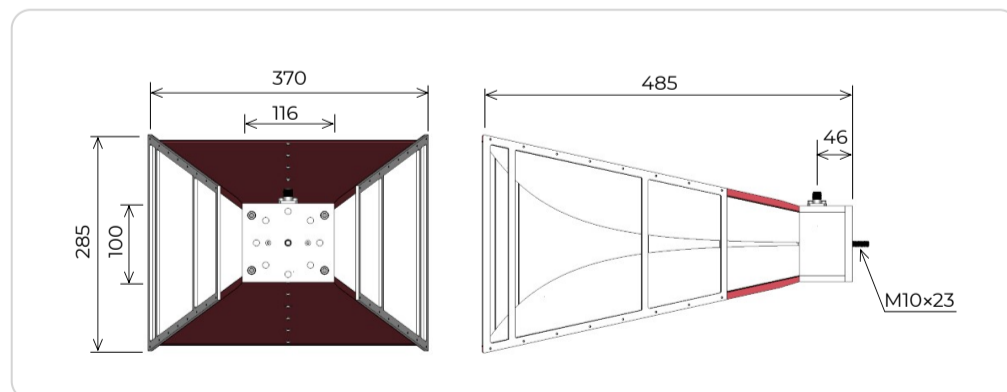

Mounting flange

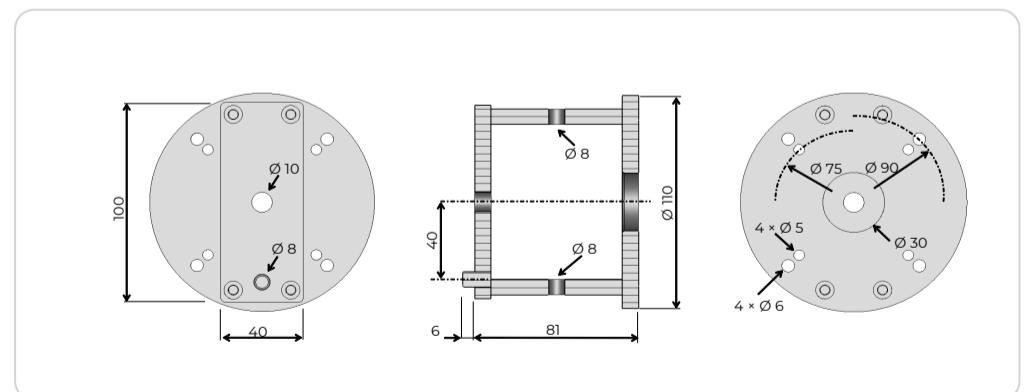

Parameters and Performance

Typical parameters

VSWR

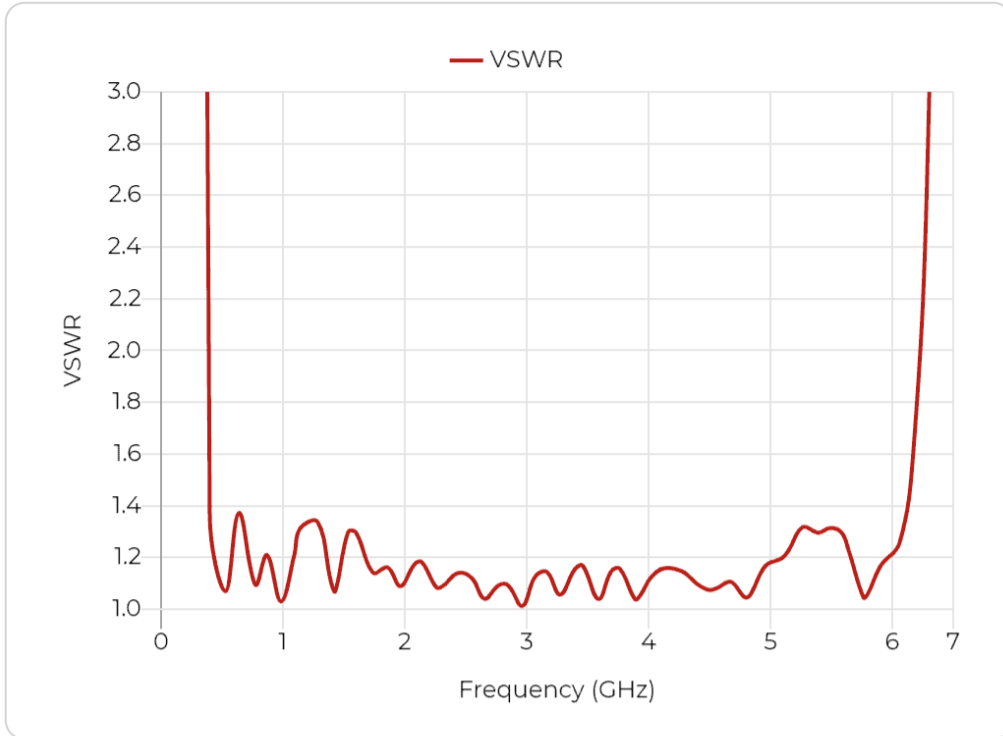

Gain

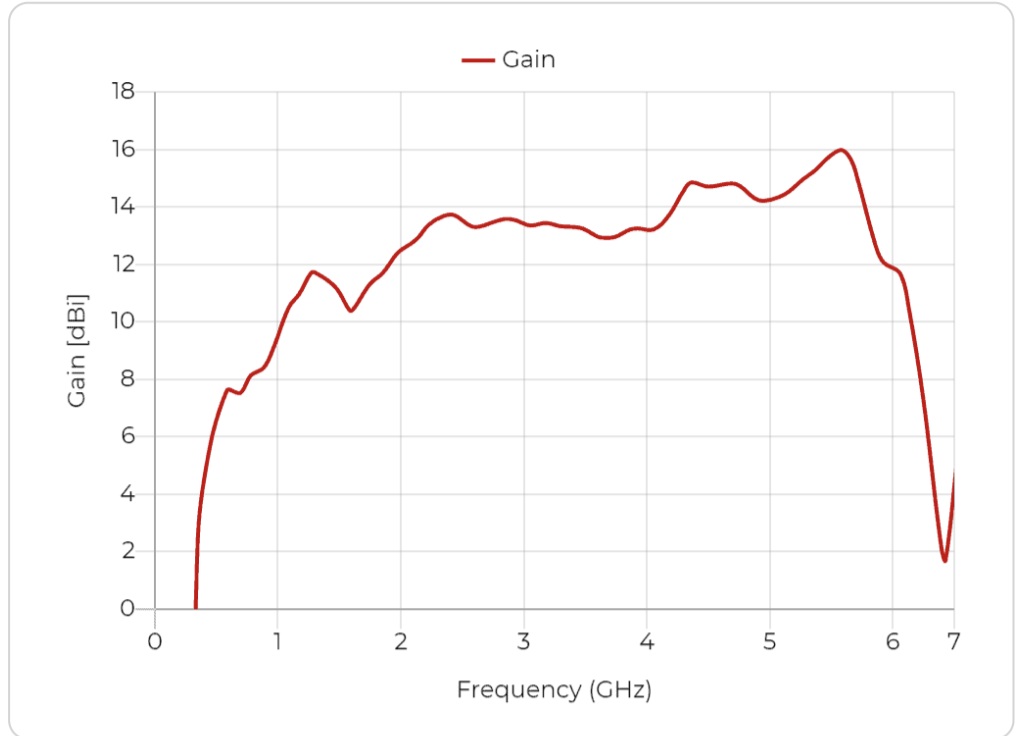

Antenna Factor

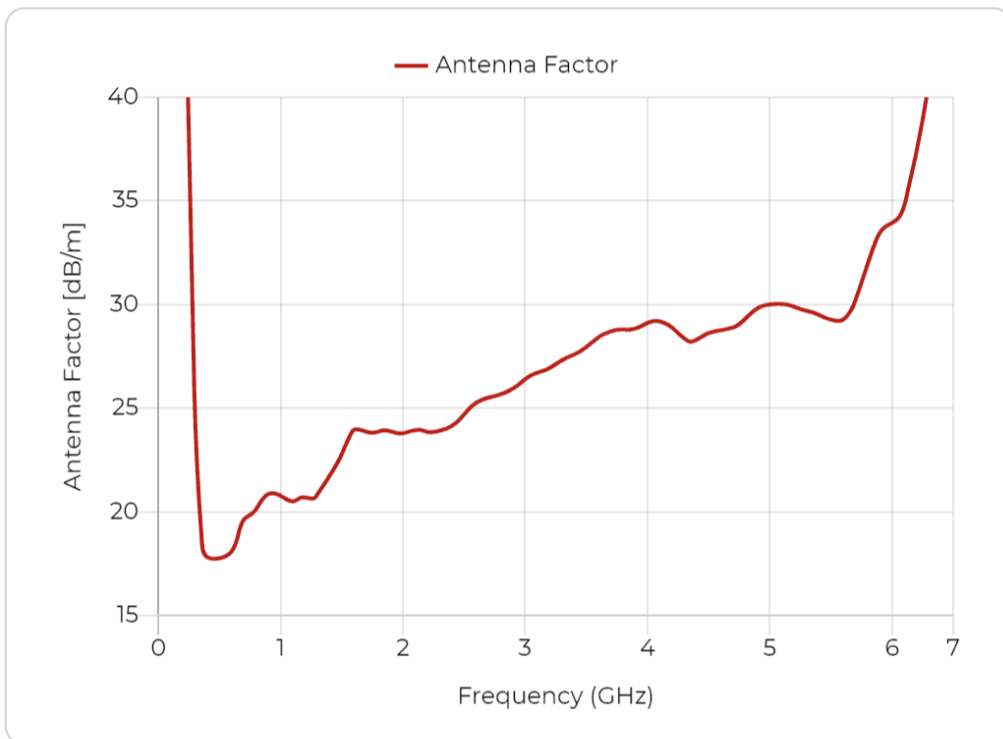

Cross Polarization

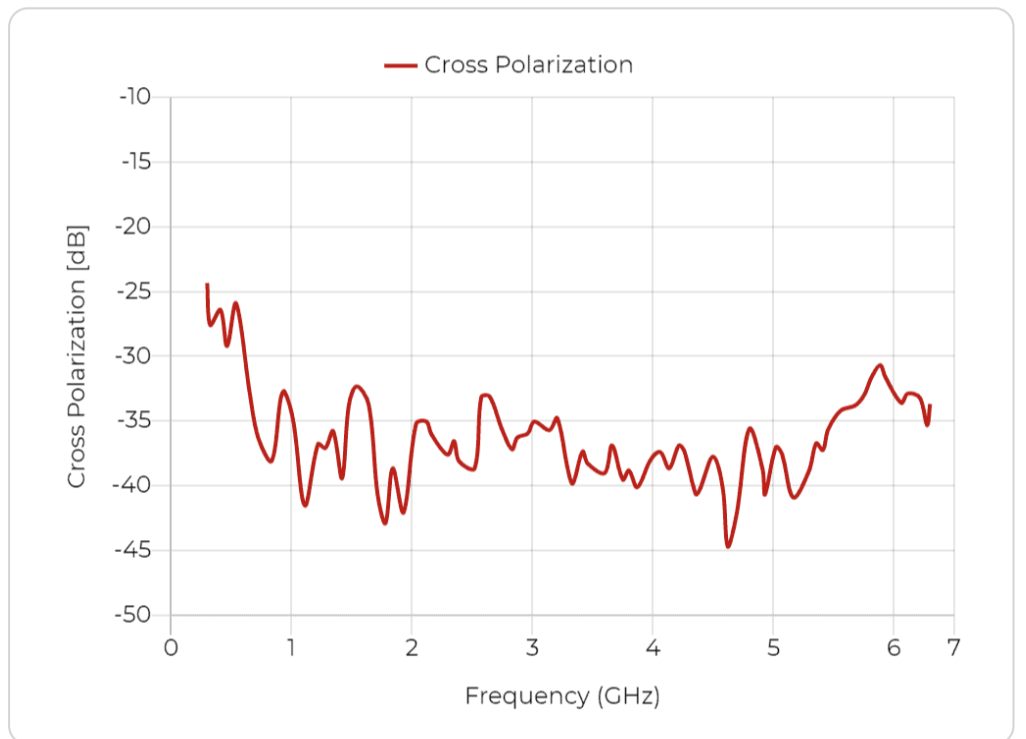

Beamwidth

Port A, E plane

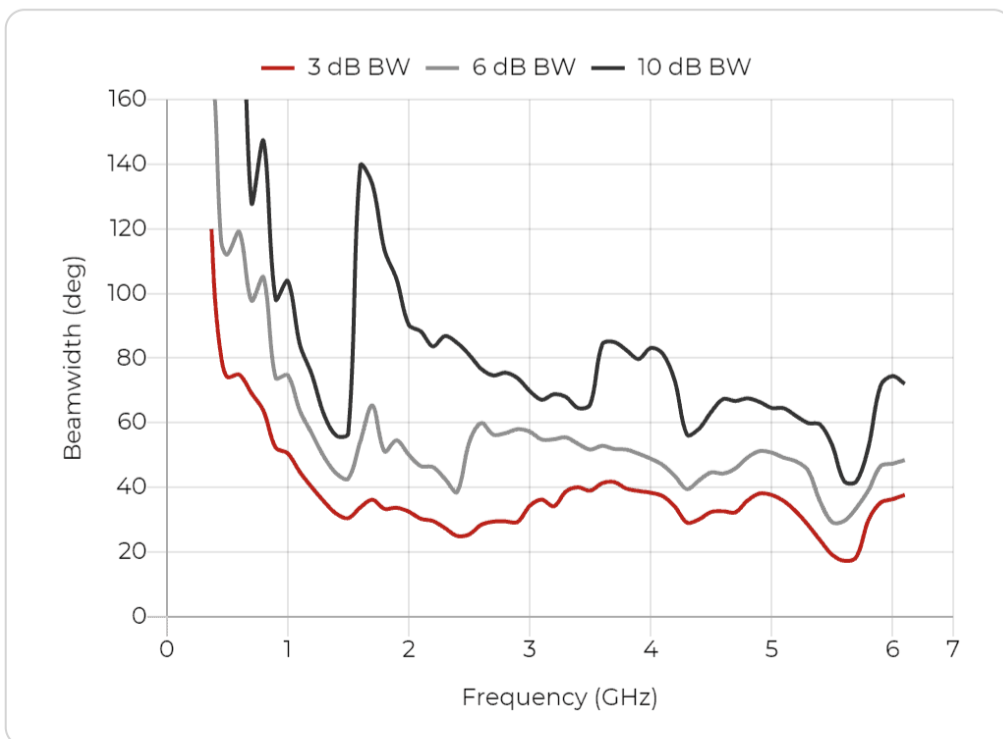

Port A, H plane

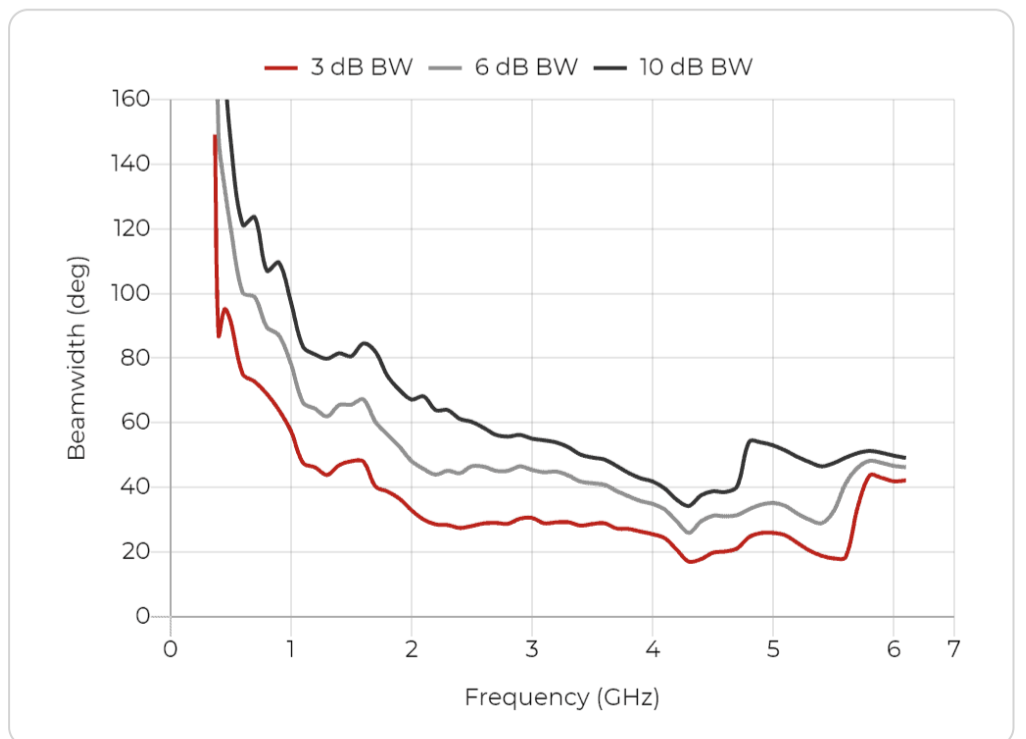

Radiation Patterns

0.37 GHz

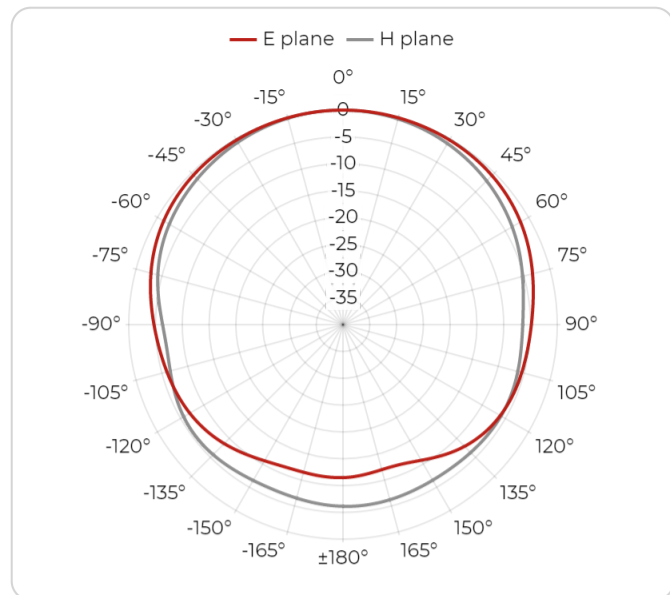

0.5 GHz

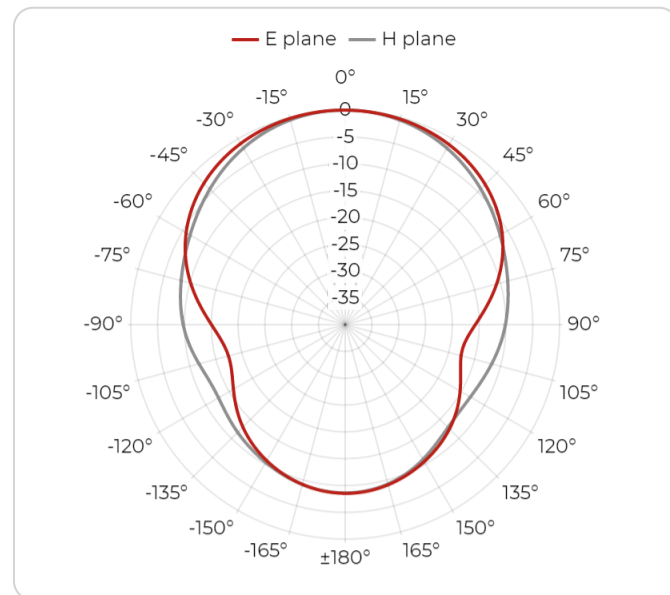

1 GHz

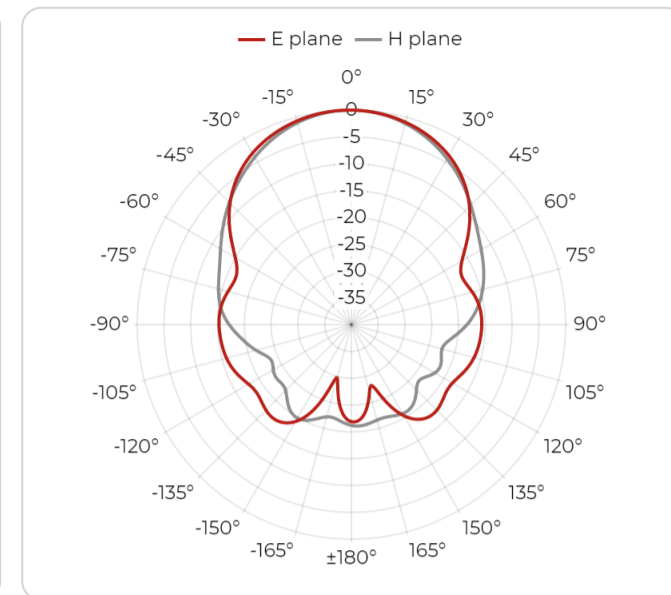

1.5 GHz

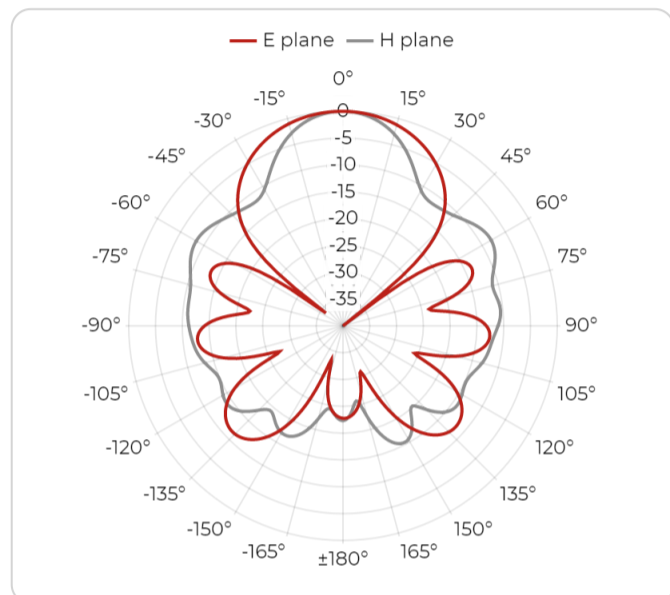

2 GHz

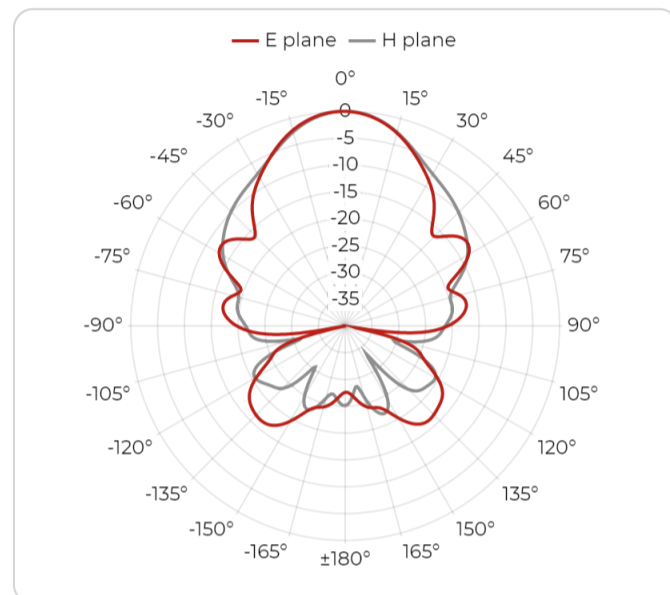

3 GHz

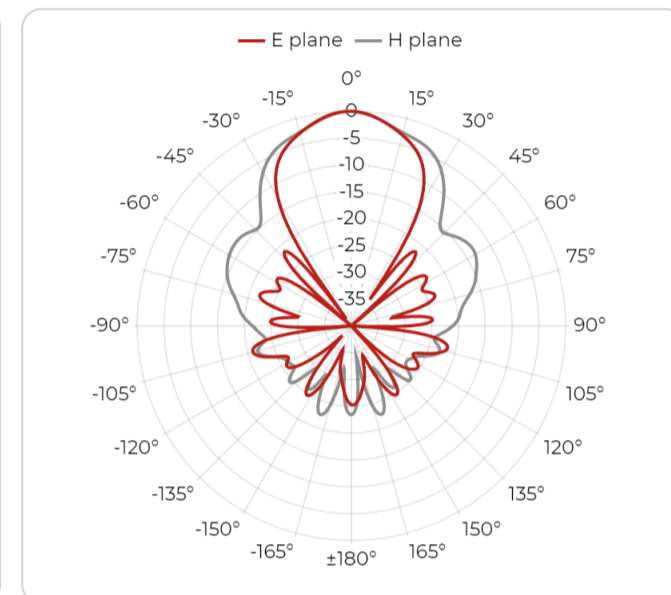

3.5 GHz

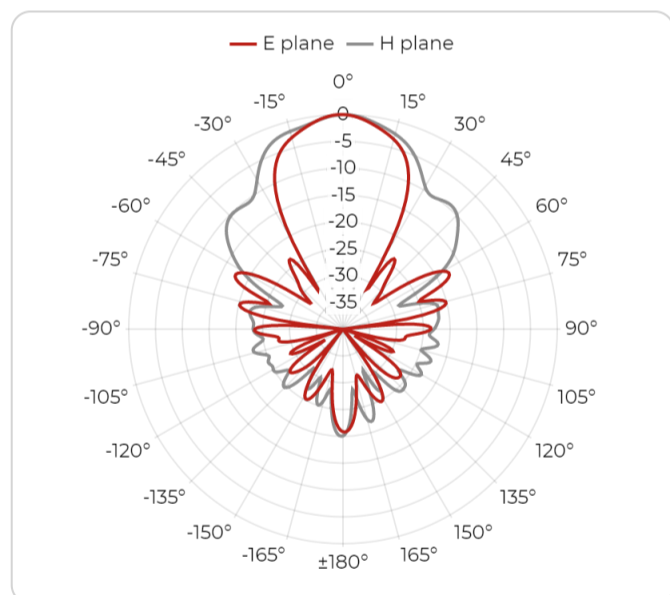

4 GHz

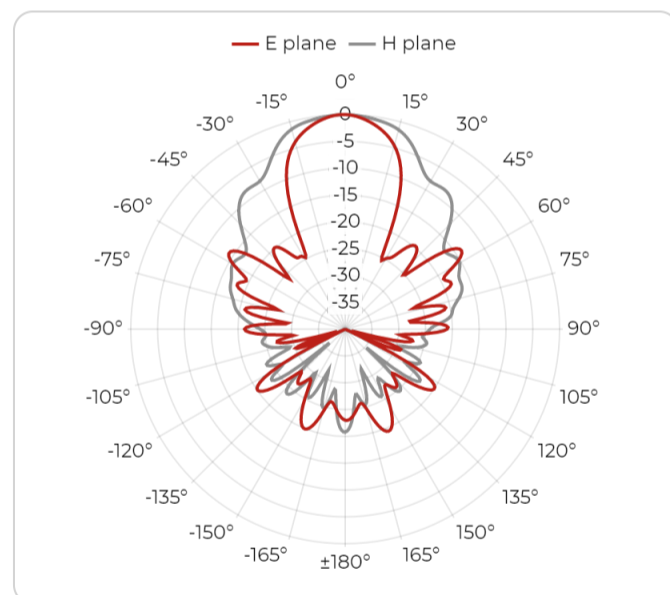

4.5 GHz

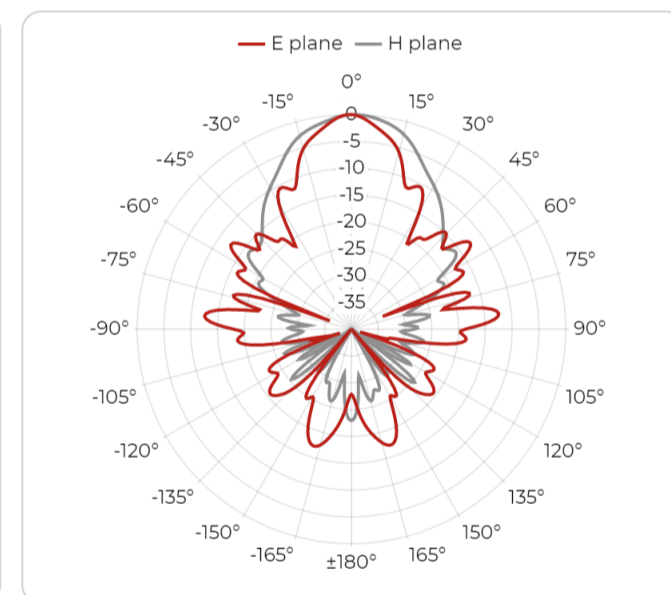

5 GHz

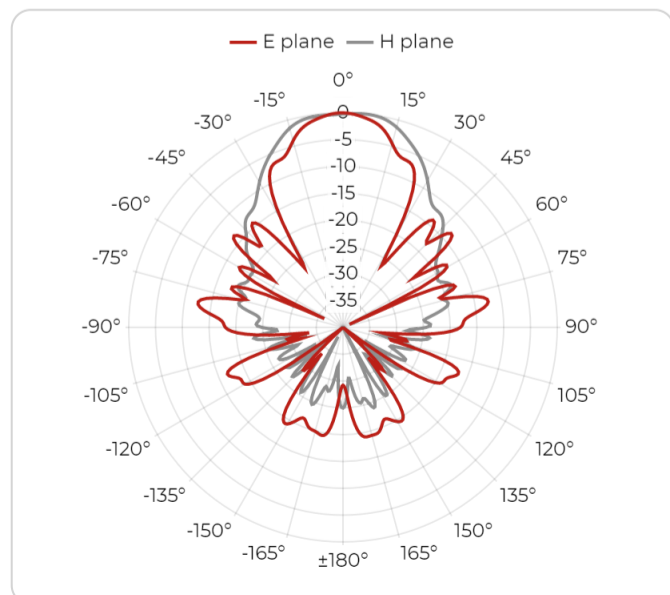

5.5 GHz

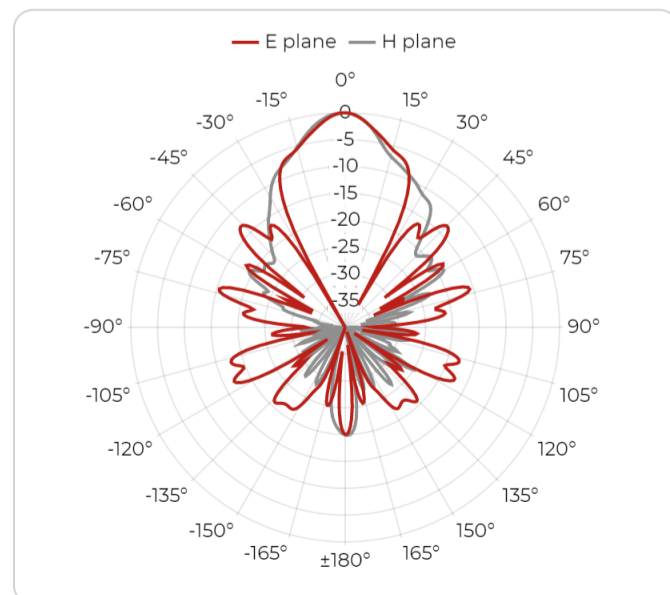

6 GHz

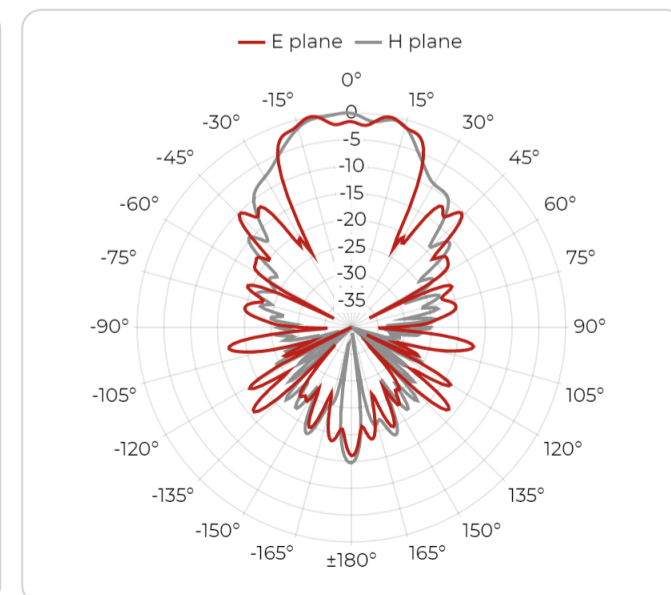

Packaging and Accessories

What's in a box

- DRH370 Antenna
- Factory calibration certificate
- Full calibration report of each antenna
- QR code accessing online portal
- Calibration test dataset (available online)
- Universal antenna mount

Accessories

- Standard mounting flange

Optional Accessories

- [FAS01 Antenna Stand](#)
- [PAS02 Antenna Stand](#)

Custom services

- Custom mounting solutions
- Custom calibration data

Manufacturer Information

About Datasheet

Product information available also online at
<https://www.rfspin.com/product/drh370/>

Data and specifications subject to change without notice.

Datasheet revision 02-2024.

© RFspin 2024

📍 Address

RFspin s.r.o.
Na Beránce 57/2
160 00 Prague 6
Czech Republic

✉ E-mail

info@rfspin.com

📞 Phone

[+420 245 008 847](tel:+420245008847)